

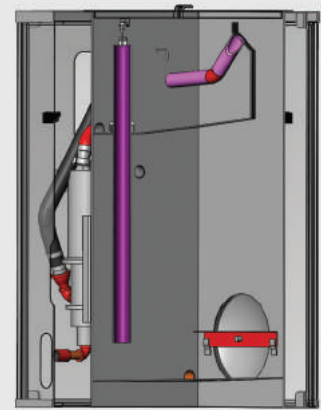

## PARTS WASHER OIL CONTROL SYSTEM

- Collects 99.5% of water free oil for possible reuse
- Removes non-soluble oil
- Extend the life of cleaning solution
- Decreases chemical & maintenance costs
- Ensures more consistent part cleanliness
- Reduces water consumption and discharge
- Removes potential bacteria buildup in the system
- Reduce maintenance time with less frequent tank dumps
- Floating skimmer ensures no adjustments are necessary
- All stainless steel construction
- Insulated tank



# PRO-SEP - Series

All specifications are subject to change without notice



CLEANING TECHNOLOGIES GROUP

RANSOHOFF • BLACKSTONE-NEY ULTRASONICS • CTG ASIA

PRO-SEP	NEW MACHINE	AFTERMARKET
VOLTAGE	24V DC with machine	110V AC/3ph/60Hz Plug
CAPACITY	181.7 L (48 Gal.)	181.7 L (48 Gal.)
FOOTPRINT (LxWxH)	32.5" x 25" x 52"	32.5" x 25" x 52"

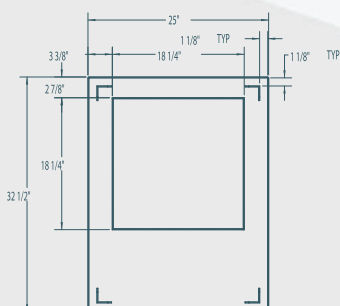

**Ransohoff**  
 (800) 248-9274  
 4933 Provident Drive  
 Cincinnati, OH 45246  
[www.ctgclean.com](http://www.ctgclean.com)

**Blackstone-NEY Ultrasonics**  
 (800) 766-6606  
 P.O. Box 220  
 9 N. Main St.  
 Jamestown, NY 14702-0220

**CTG Asia**  
 (86)0512-66161698  
 56 Songshan Road  
 Suzhou New District  
 Jiangsu Province, China PRC: 215151



# CLEANING TECHNOLOGIES GROUP

RANSOHOFF • BLACKSTONE-NEY ULTRASONICS CTG ASIA

PRO-SEP is an advanced technology oil control system, not just another method of surface oil skimming. PRO-SEP assures the maximum life of your cleaning solution. It automatically separates and removes all non-soluble oils from aqueous washer solutions.

With PRO-SEP you will realize significant cost savings in the operation of your parts washer. Costs such as chemicals, maintenance labor, and energy.

Unlike conventional oil separation devices, the PRO-SEP allows the oil to be collected in a much smaller volume and then discharged from the system more rapidly. The benefits realized are a significant reduction in the potential for bacteria growth within the separation tank while also allowing collected oil to discharge with much less in the way of encapsulated water residual.

A uniquely designed floating collection (pickup) device is also included which mounts directly in the wash tank of the parts washer. This device provides high volume skimming of the solution bath surface while automatically compensating for fluctuations in bath level.

